

KENTMASTER

Kentmaster .22 calibre Cylindrical Humane Slaughter Tool CY1



User Manual/ Original Instructions



Do not use this tool until you have read and fully understood the instructions detailed in this manual.

Essential Safety Instructions

Carefully Read the entire User Guide before using the Tool and retain for future reference.



WARNING

Never Allow untrained personnel to use this tool.

- Do not use this tool without safety glasses and hearing protection.
- Never point the tool at anything other than the intended target.
- Never place hands or any other part of the body in front of the muzzle/ bolt end of the tool.
- Never indulge in horseplay.
- Never leave loaded tool unattended.
- Unload the tool if it is not to be used.
- Always ensure the tool is cleaned and maintained properly.
- Never Air Shoot the tool.
- Clean and Inspect the tool daily.
- Replace worn or broken components.
- Always use components that are recommended and supplied by Kentmaster only.
- Never modify or customise the tool.
- Never allow the tool to be tampered with.
- Only use cartridges that are recommended by Kentmaster.
- The stunner and cartridges must be locked away separately from each other when not in use
- Cartridges must be stored in cool, dry conditions. Exposure to excessive amounts of moisture may affect their performance.
- Max Noise Value when using the most powerful cartridge permitted (.22 Black for the CY1) is 86.3Db+/- . NB This figure may vary depending on customer environment.
- The maximum velocity generated with .22 Black is 61m/sec.
- Do not use the stunner more than four times in a one minute cycle in order to avoid excessive heat build-up.

Cartridge Selection

Cartridge Designation	Usage/ Recommendation
.22 Kentmaster Pink	Small animals such as sheep
.22 Kentmaster Purple	Smaller cattle and Pigs
.22 Kentmaster Green	Medium sized cattle
.22 Kentmaster Red	For Heavy Cattle
.22 Kentmaster Black	For Heavy Cattle and Bulls

Kentmaster Stunners are used worldwide in many abattoirs/slaughterhouses for all species including cattle and buffalo, sheep and goat, pig, camel, and many others including turkey. The stunners are also used for euthanising animals in emergency situations in and near to feedlots and by pastoral companies, breeders, transport companies, veterinarians and live export shipping companies. Kentmaster's primary requirement is to ensure good animal welfare practices can be carried out no matter the situation and/ or location.



Safe Operating Instructions for the Kentmaster Model CY1 .22 calibre Cylindrical Humane Slaughter Tool

1. Opening the Breech
(A) Twist the Firing Cap anti-clockwise



- (B) Lift upwards. Hinge the Firing Cap back down to open the breech.



- (C) The action of opening the breech will operate the extractor and partially lift the spent (fired) cartridge. See (5) Extraction.



WARNING

In case of uncertainty as to whether the cartridge has detonated or not, always treat it as a Live cartridge (Reference Safe Removal of Live Cartridge).

2. Inserting the Cartridge

Before inserting the cartridge into the breech, ensure the bolt has fully returned. If not, the tool should be removed from Operation and returned for corrective maintenance.



3. Safe Preparation prior to Firing

The Firing pin should only be cocked (engaged) at the point of operation immediately prior to Stunning (D).

4. Firing

Position squarely and securely on animal's head in the recommended position shown (Ref diagrams shown below). Squeeze the trigger to fire. In the event that the stun cannot be effected, the cartridge should be removed (Ref Safe Removal of Live cartridges)

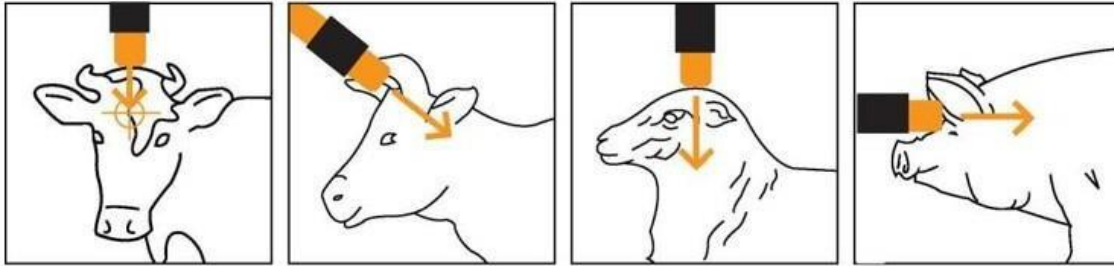

CATTLE, CALVES

Place muzzle as indicated, in the middle of the forehead at the intersection of two imaginary lines drawn between the eyes and the centre of the base of the opposite horns.

SHEEP

For hornless sheep, place muzzle in the centre of the top of the head. For horned sheep and goats, the muzzle should be placed behind the ridge between the horns, centrally aimed towards the base of the tongue.

PIGS

Place muzzle approx. 20mm width above the eyes, halfway across the forehead, aiming up slightly.

5. Extraction

The action of opening the breech will operate the extractor and partially lift the spent (fired) cartridge (E). The stunner is now ready to reload.



Safe Removal of the Cartridge

It may be necessary to remove a live cartridge from the Breech. Extract the live cartridge carefully as advised from the breech and return to its box. If the cartridge becomes stuck in the breech or the extractor fails to operate, the stunner should be returned to maintenance for Safe removal. Maintenance operatives should be warned that a Live cartridge is in the breech. The breech should be open so the tool cannot fire and will be safe in transit to the maintenance department. If a misfire has occurred, it is advisable to wait for 30 seconds before the removal procedure is implemented in case a delayed firing should occur. During this time the tool should not be pointed at oneself or any other person. After 30 seconds the live cartridge can be removed. It should be placed in a container filled with water. Do not attempt to reuse the misfired cartridge. Regular misfires indicate that the stunner is unsuitable for operation and should be returned to the maintenance dept for investigation.

Cleaning and maintenance for the .22 calibre Kentmaster CY1 Cylindrical Humane Slaughter Tool

Guidance on daily cleaning and maintenance

DO NOT ATTEMPT TO USE THIS STUNNING TOOL UNTIL YOU HAVE READ AND UNDERSTOOD THESE INSTRUCTIONS. ONLY USE SPARE PARTS RECOMMENDED BY KENTMASTER, WHICH ARE AVAILABLE FROM YOUR LOCAL KENTMASTER SUPPLIER.

Cleaning - Daily

- (1) Open the breech and check there is not a live cartridge in the chamber.
- (2) Unscrew the muzzle from the barrel. If the muzzle cannot be removed by hand, then grip the muzzle by the two flats in a vice fitted with soft jaws and unscrew in an anti-clockwise direction.
- (3) Remove the bolt assembly from the barrel, it should be easily removable by hand. If not, grip the barrel across its flat surfaces in a vice fitted with soft jaws. Open the breech and insert the push rod through the cartridge chamber to gently tap out the bolt.
- (4) Clean inside of barrel with barrel brush cleaner to remove the day's soft debris.

Insert breech cleaner into the breech piston bore to clean out the soft debris.

A suitable light machine oil (e.g. Bel-Ray Non Toxic Air Line Oil) should be used and it must have a high flashpoint. This can be used to soften the debris and provide lubrication.

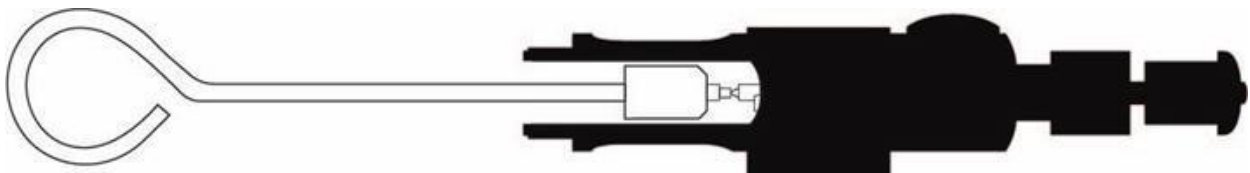

- (5) Remove washers and bolt return collars from the bolt and remove carbon from the bolt with a brush or wire wheel. Wipe the bolt clean with an oily cloth. Wipe away any soft debris from the collars and washers and examine for wear. Examine bolt return collars and washers.

Daily Maintenance Checks

(1) Thick Washer (Front). (part no. AB3/ key no. 22)

This is the washer situated at the front poleaxe end of the bolt.

This prevents the adjacent bolt return collar next to it from extruding through the muzzle bore. Once this washer displays any wear in the bore or around the outside then it should be replaced.

(2) Thin Washer (Rear). (part no. AB5/ key no. 20)

This washer is situated behind the rearmost bolt return collar in front of the bolt flange. Once this washer displays any wear in the bore or around the outside then it should be replaced.

(3) Bolt Return Collar (part no. AB4/ key no. 21)

There are 8 collars on the bolt. The front two collars and the rearmost collar will wear more quickly than the other collars. These should be moved to a central position so that they all wear at an even rate.

This will provide greater longevity. By maintaining the Thick and Thin washer and cycling the bolt return collars this should give the collars a life of approximately 5000 shots.

ALWAYS MAINTAIN COLLARS AND WASHERS IN GOOD CONDITION TO MAXIMISE BOLT PERFORMANCE AND TO PREVENT THE BOLT FROM STICKING IN THE ANIMAL'S HEAD.

(4) Locking Collar (part no. AB2/ key no. 23)

Replace if broken, worn or torn. If this collar is in poor condition or not present, then extreme wear to bolt return collars will occur.

Cleaning the barrel bore at the Breech end.

Most powder debris accumulates at the breech end of the barrel. Cleaning thoroughly in this area allows for a smooth bolt return.

To use the Barrel Breech end Cleaner -

(1) Grip the Barrel Breech end cleaner in an upright position with the widest end uppermost in a vice.

(2) Lower the barrel down the cleaner until it rests on the breech face.

(3) Apply sideways pressure against the barrel so that the cleaner blade removes any powder debris. Maintain this pressure whilst rotating the barrel until the area has been cleared of debris.

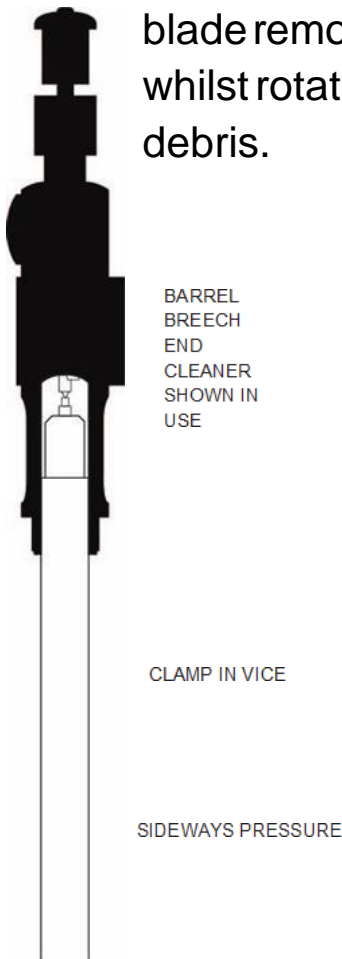

RE-ASSEMBLE BOLT ASSEMBLY AND MUZZLE.

Wipe down all metal parts with a lightly oiled cloth. Do not oil the cartridge chamber.

Insert the bolt assembly into the barrel.

Insert the locking collar into the muzzle against the face of the bore. Locate the bolt into the bolt bore in the muzzle by pushing down on the thick washer (front) and compressing the bolt return collars until the muzzle thread can be engaged. Screw the muzzle clockwise by hand until it is fully secured.

Troubleshooting.

Misfires.

Misfires may be caused by;

- (1) Broken or worn Firing Pin (part no. B7/ key no.7)
- (2) Broken or worn Firing Pin Spring (part no. B5/ key no. 5)
- (3) Worn cartridge chamber.
- (4) Damp or contaminated cartridges.
- (5) Excessive oil in cartridge chamber.

Loss of power or low power.

Loss of power or low power may be caused by;

- (1) incorrect cartridge selection.
- (2) Poor or lack of cleaning and maintenance.
- (3) Bolt Return Collars and Washers require replacement.
- (4) Bolt bent or damaged. NB; Do not grind bolt outside diameter to sharpen.

Not only will any of the above factors result in a poor stun but they can also result in the bolt sticking in the head of the animal.

IF ANY FURTHER INFORMATION, ADVICE OR ASSISTANCE IS REQUIRED PLEASE CONTACT YOUR LOCAL KENTMASTER DISTRIBUTOR. YOU MAY NEED TO QUOTE THE SERIAL NUMBER, WHICH IS LOCATED ON THE FIRING CAP close to the trigger. This will typically be a 7 digit reference, whereby the first two numbers denote the year of manufacture. The second two; the month of manufacture and the 5,6, and 7th numbers represent the sequential manufacturing number. As an example, the reference 1903024 refers to the 24th tool made in March 2019.

All Kentmaster stunners are proof tested at the Birmingham Proof House in England before general sale and carry the Proof House mark.



BNP

Proof House mark.

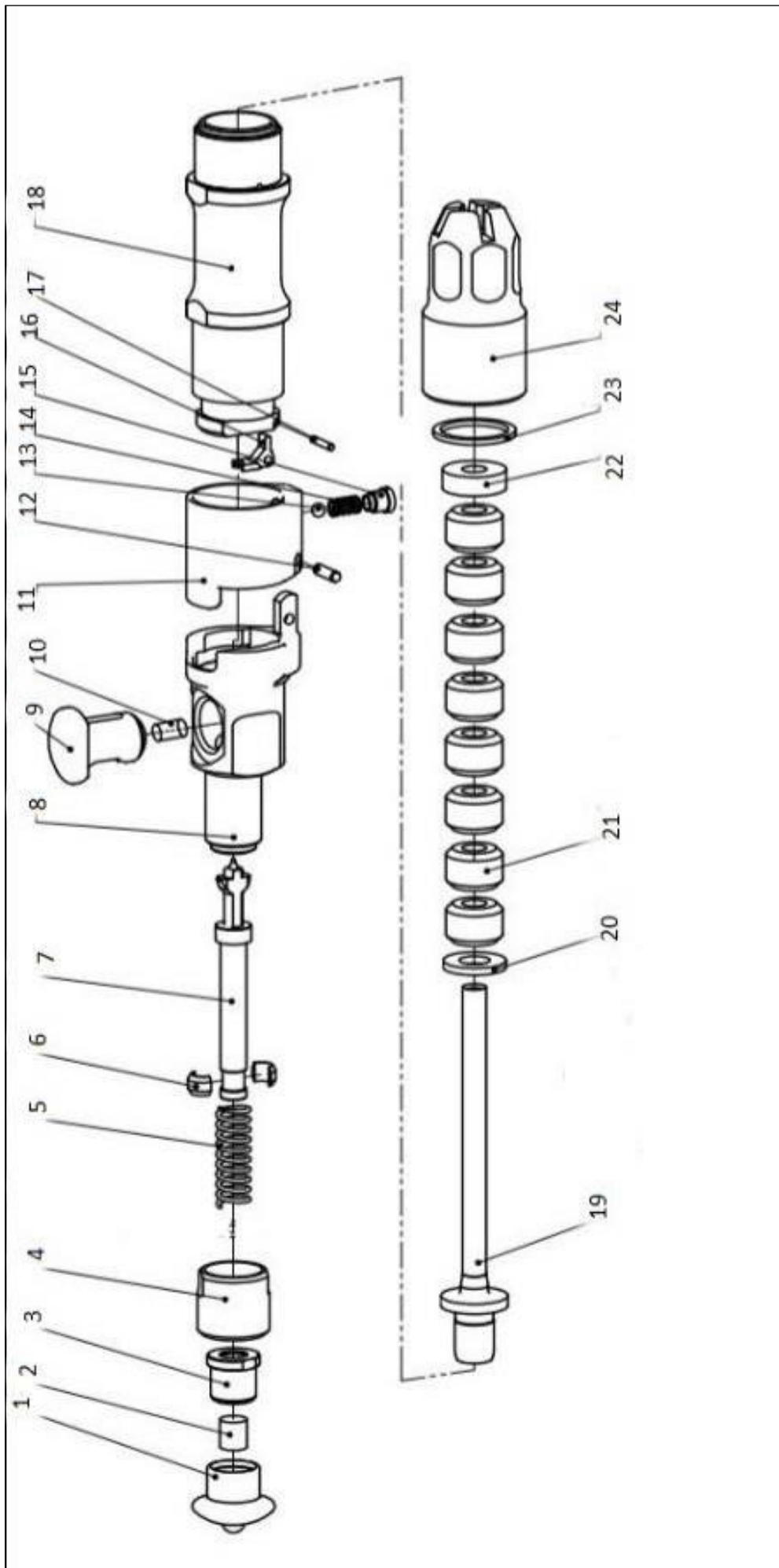

Kentmaster .22 Calibre CY1 Cylindrical Stunner Parts List

Part No.	Key No.	Item
B1	1	Pull Cap
B2	2	Pull Cap Spring
B3	3	Pull Cap Sleeve
B4	4	Spring Cap
B5	5	Firing Spring
B6	6	Split Collar (Pair)
B7	7	Firing Pin
B8	8	Firing Cap
B9	9	Trigger
B10	10	Trigger Spring
B11	11	Retaining Cap
B12	12	Hinge Pin
B13	13	Retaining Ball
B14	14	Ball Plunger Spring
B15	15	Ball Plunger Cap
B16	16	Extractor
B17	17	Extractor Pin
B18	18	Barrel/ Breech
AB6	19	Captive Bolt
AB5	20	Thin Washer (Rear)
AB4	21	Bolt Return Collar
AB3	22	Thick Washer (Front)
AB2	23	Locking Collar
AB1	24	Muzzle
D1		Barrel/ Breech End Cleaner
D2		Barrel Brush
D3		Small Brush
D4		Piston Bore Cleaner
D5		Push Rod
D6		Screwdriver



Safenet Limited

Denford Garage, Denford, Kettering, Northants., NN14 4EQ, U.K.

Tel: +44 1832 732174

e-mail: office@safenet.co.uk

Website: www.safenet.co.uk

European Notified Body 1674

EC Type Examination Certificate

This is to certify that

Kentmaster Mfg. Co., Inc.

1801 South Mountain Avenue, Monrovia, CA, 91016, USA

Has had a range of Humane Slaughter Tools examined with regard to the Directive 2006/42/EC, as amended.

In respect of the **HG1-22 and CY1-22**

Manufactured by:

Sichuan Nanshan Powder Actuated Fastening System Co., Ltd.

Nanxi, Yibin, Sichuan, China, Zip Code: 644100

1. The technical file contains all the relevant documents and information.
2. Having verified that the appropriate tests have been conducted we confirm that:
 - 2.1. The standards and harmonised standards, including EN 15895:2011, have been applied correctly.
 - 2.2. The following models are included within the certification HG1-22, HG1-25, CY1-22 and CY1-25.

Certificate Number: 8041100519a

Date: 18/11/2019

Signed for Safenet Limited

Peter McNicol
Technical Manager



Machinery
Directive
Number
1674

This document remains the property of Safenet Ltd and will be returned to them if so requested.
The client is required to request a review to ensure continued compliance of the machinery on a 5 yearly basis to check for changes in the state of the art and validity of the certificate.

EC Declaration of Conformity

We Kentmaster Mfg. Co., Inc.
Of
1801 South Mountain Avenue, Monrovia, CA, 91016, USA

Declare that the Humane Slaughter Tools

Models: HG1-22, HG1-25, CY1-22 and CY1-25

Manufactured by:

Sichuan Nanshan Powder Actuated Fastening System Co., Ltd.

Nanxi, Yibin, Sichuan, China, Zip Code: 644100

Meet all the relevant requirements of the following European Directives:

2006/42/EC Machinery Directive

Using the following transposed standard:

EN 15895:2011

Having been type examined to the requirements of the Machinery Directives 2006/42/EC by:

Safenet Limited
c/o Denford Garage
Denford
Kettering
Northamptonshire
NN14 4EQ, UK

Notification Number: 1674

Certificate Number: 8041100519a

Safenet is authorised to compile the technical file in the European community.

W R Lau
Signed _____ Date 18/11/2019
SENIOR VICE PRESIDENT _____
Position _____ Place MONROVIA, USA



Kentmaster Worldwide Locations:

AUSTRALIA | BRAZIL | IRELAND | NEW ZEALAND | SOUTH AFRICA | UNITED KINGDOM | UNITED STATES
| ARGENTINA | CHINA

Kentmaster has international locations available to serve you. Please contact us for a list of our partners in your specific geographical area. We work with our partners to serve you expeditiously and look forward to serving your needs.

United States

Kentmaster Headquarters: Kentmaster Mfg. Co., Inc 1801 South Mountain Ave.
Monrovia, CA, 91016 Phone: 1 (626) 359-8888 Fax: 1 (626) 303-5151 Email: Info@kentmaster.com
Kentmaster - Omaha, Nebraska 4417 South 139th Street Omaha, NE, 68137 Phone: 1 (402) 896-3355 Fax: 1 (402) 896-3311 Email: Omaha@kentmaster.com

Australia

Kentmaster Equipment (Aust) PTY.LTD.
Unit 2 24 Central Court
Hillcrest Qld. 4118
Phone:(07) 3806-8400
Fax:(07) 3806-7933
Email: australia@kentmaster.com.au

Brazil

Kentmaster do Brasil, Ltda.
Av. Dr. Joao Teodoro No. 805 Bairro De Vila Rezende 13405-240 Piracicaba, SP Phone: (019) 3 413 3113 Phone (Alt): (019) 3 983 4973 Fax: (019) 3 413 3113 Email: Brazil@kentmaster.com

Ireland

Kentmaster (IRL) LTD.
Benamore, Dublin Road.
Roscrea,
CO, Tipperary Phone: (353) 0505-23292 Fax: (353) 0505-23299 Email: Ireland@kentmaster.com

New Zealand

Kentmaster Equipment (NZ) LTD.
1/88 Ford Road Onekawa Napier 4110
Mailing address:
PO. Box 3466
Taradale Road
Napier 4142
Phone:(06) 835-2471
Fax:(06) 835-6904
Email :NewZealand@kentmaster.com

South Africa

Kentmaster South Africa (PTY) LTD. Johannesburg - S. Africa Unit 54 Sunnyrock Park Sunrock Close, Germiston
Mailing address:
Johannesburg - S. Africa
PO. Box 7030
Primerose Hill, 1417 Phone: (27) 11-455-3748 Fax: (27) 11-455-3749
Email: SouthAfrica@kentmaster.com

United Kingdom

Kentmaster (UK) LTD.
Unit 301
Hartlebury Trading Estate Hartlebury
Worcestershire DY10 4JB Phone: (44) 129-925-3394 Fax: (44) 129-925-1271 Email:
UK@kentmaster.com

KENTMASTER

Argentina

Kentmaster Argentina S.A.
Luis Maria Drago 190
(1607) Villa Adelina
Buenos Aires - Argentina
Tel: +(54) 11 4763 0473
Email: Argentina@kentmaster.com

China

Kentmaster Mfg.Inc. China
No.28, Linhe avenue, Linhe industrial development zone
Shunyi district, Beijing, China
Tel: +86 188 888 23139
Email: China@kentmaster.com